

- F Notice de montage ● GB Installation instructions
- E Manual de instalación ● I Istruzioni di montaggio
- NL Montage-instructies ● D Montageanleitung

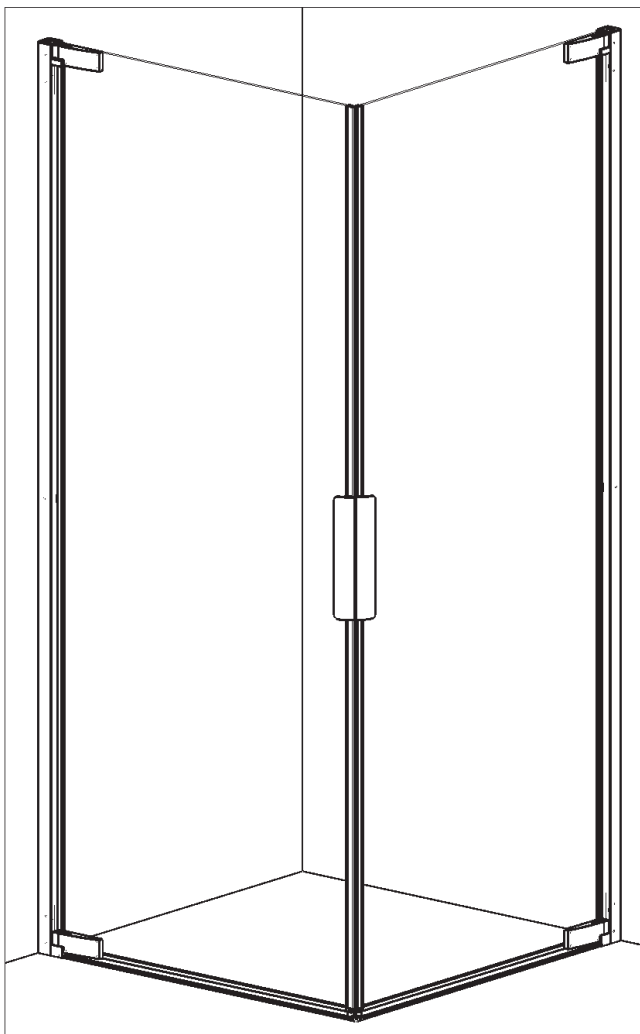







Notre service technique est à votre écoute aux numéros qui sont au dos de cette notice d'installation

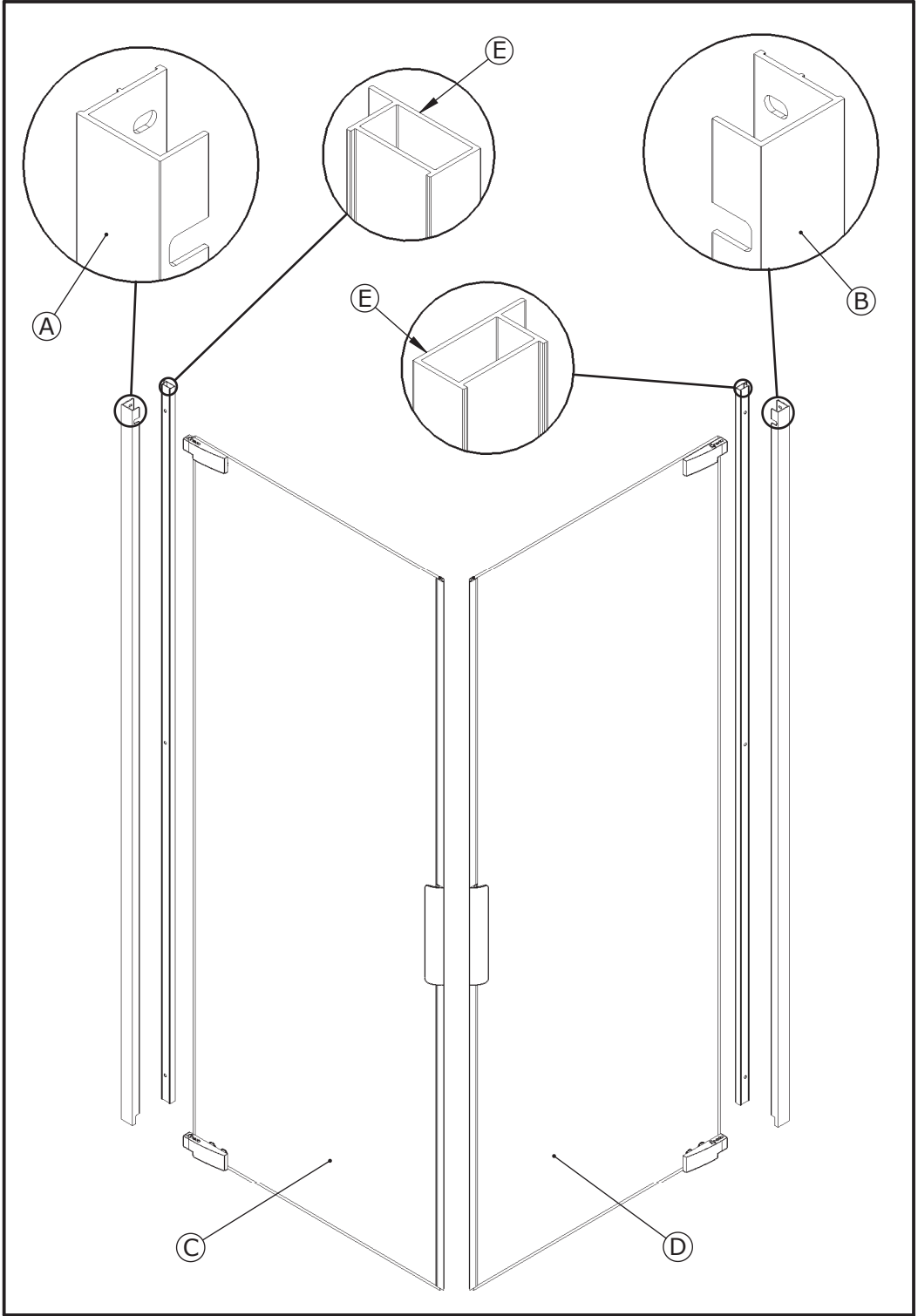

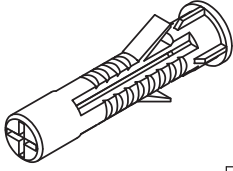
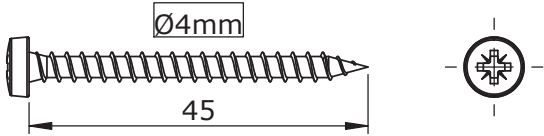
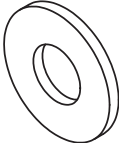
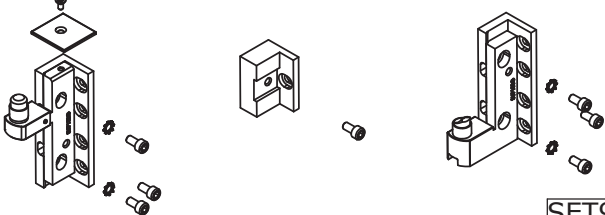
- F Attention aux étapes :
- GB Check installation steps :
- E Atención a los pasos :
- I Attenzione ai passi :
- NL Aandacht voor de stappen :
- D Achtung vor den Schritten :

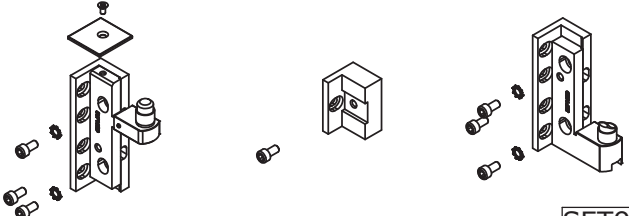
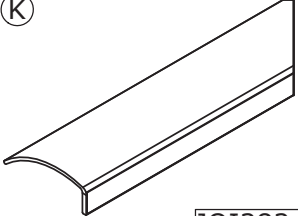
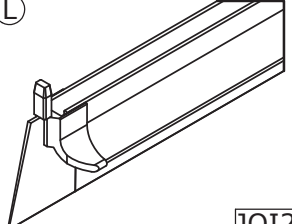
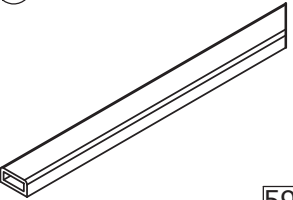
P. 5 - 14 - 20

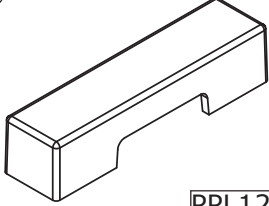

<p>(F) X10</p>  <p>CHE02</p>	<p>(G) X10</p>  <p>1 = 1</p> <p>VIS210</p>	
<p>(H) X10</p>  <p>RON34</p>	<p>(I) X1</p>  <p>SET91G</p>	
<p>(J) X6</p>  <p>PPL1075</p>	<p>(K) X1</p>  <p>SET91D</p>	
<p>(K) X2</p>  <p>JOI282-01</p>	<p>(L) X2</p>  <p>JOI285</p>	<p>(M) X2</p>  <p>5918</p>
<p>(N) X1</p>  <p>PPL665</p>	<p>(O) X4</p>  <p>PPL1226</p>	<p>(P) X8</p>  <p>PPL1052</p>

Les quantités données sont les quantités utiles au montage. les sachets fournis contiennent des pièces supplémentaires.
The quantities given are what are required for the installation. There may be some surplus in the package provide.

Matériel nécessaire
 Tools required
 Herramientas necesarias
 Materiale necessario
 Benodigd gereedschap
 Werkzeuge Erforderlich

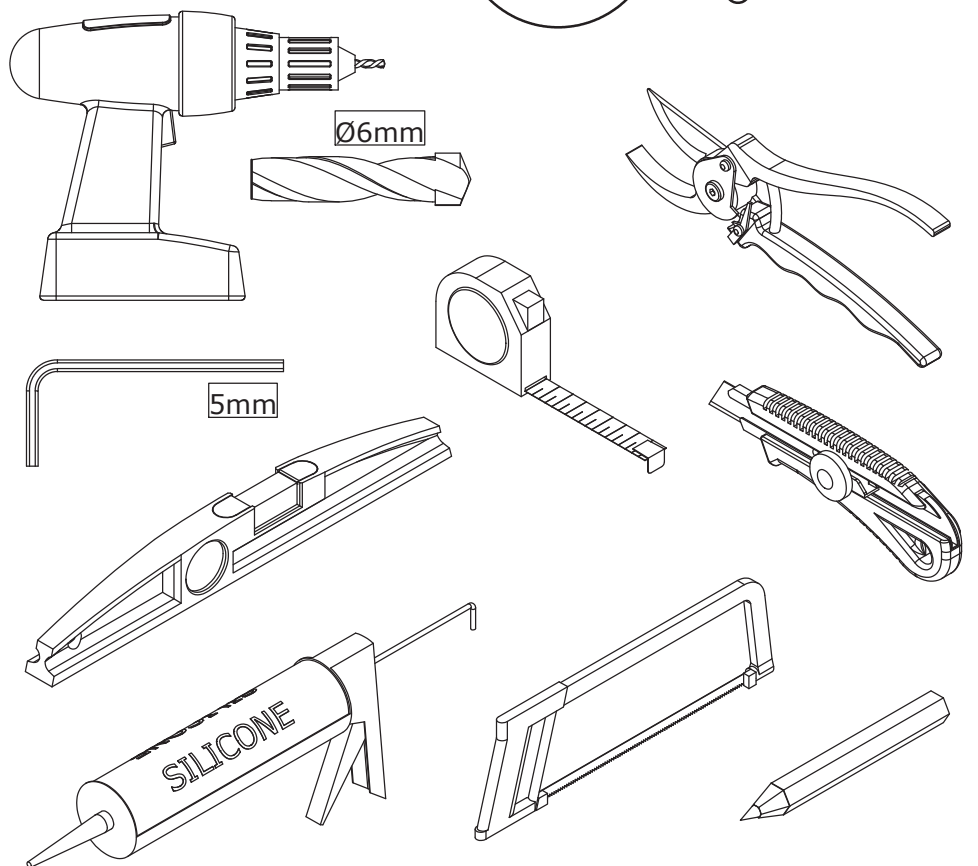

Utiliser un silicone adapté au matériau de chaque support (faïence, acrylique, etc.)
 Use a silicone sealant that is intended for the surrounding materials (ceramic, acrylic, etc.)
 Usar una silicona adecuada para cada tipo de material (loza, acrílico, etc.)
 Utilizzare un silicone adatto a qualsiasi materiale (ceramica, acrilico, ecc.)
 Gebruik siliconenkit die geschikt is voor iedere ondergrond (tegelwerk, acryl, etc.)
 Für das jeweilige Trägermaterial (Stein, Acryl usw.) geeignetes Silikon verwenden.



01

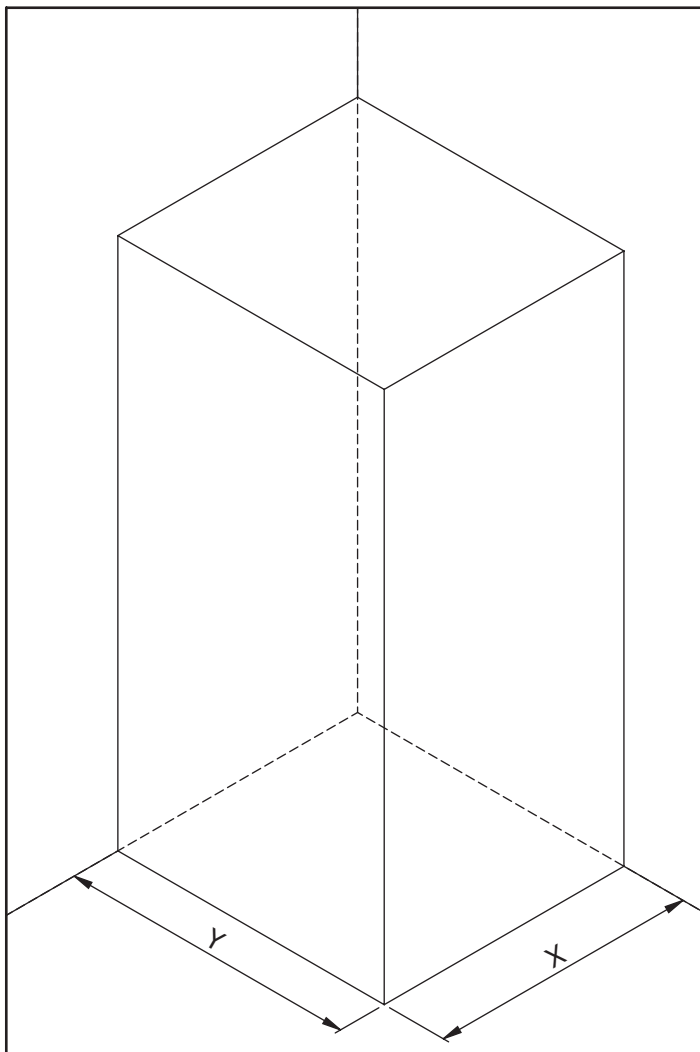

X	
800	775-790mm
900	875-890mm
1000	975-990mm

Y	
800	775-790mm
900	875-890mm
1000	975-990mm

02

Côté extérieur
Outside
Exterior
Esterno
Buitenkant
Außen

2

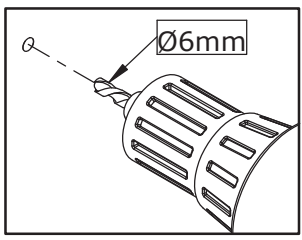

X10

Côté extérieur
Outside
Exterior
Esterno
Buitenkant
Außen

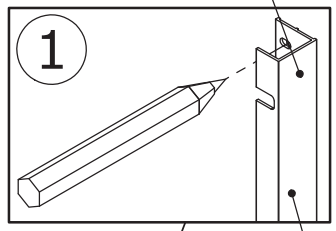
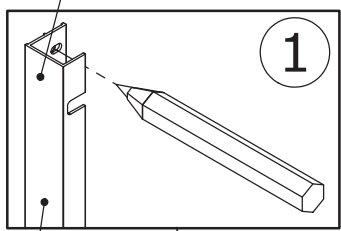

A

B

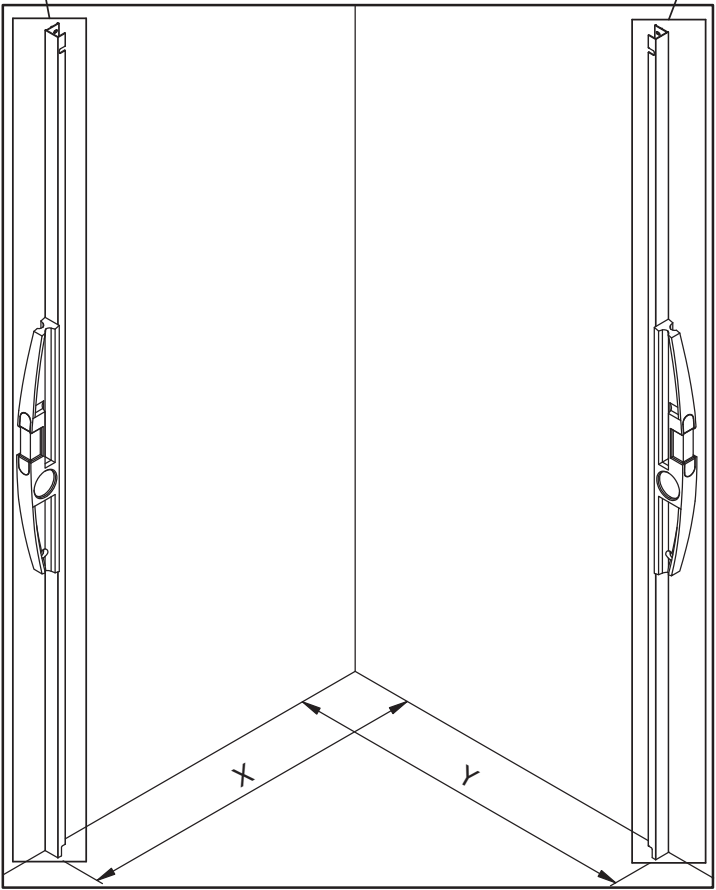

03

VUE INTERIEURE
 INTERIOR VIEW
 VISTA INTERIOR
 VISTA INTERNA
 BINNENZICHT
 INNENANSICHT

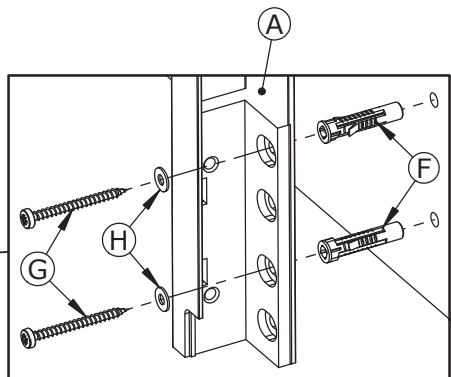
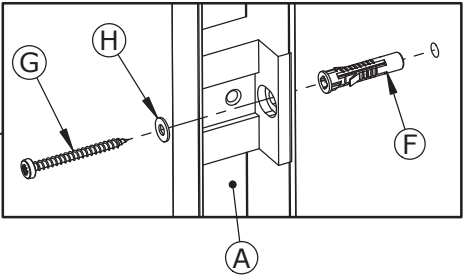
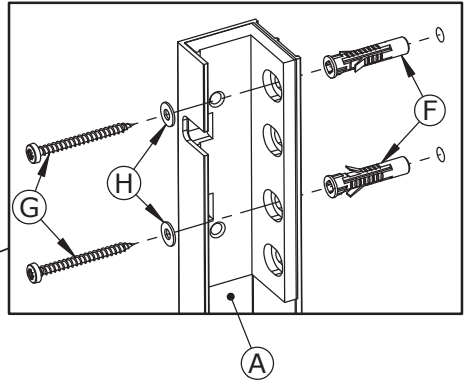

04

VUE INTERIEURE
INTERIOR VIEW
VISTA INTERIOR
VISTA INTERNA
BINNENZICHT
INNENANSICHT

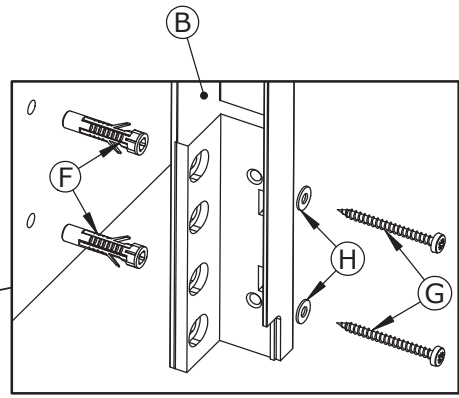
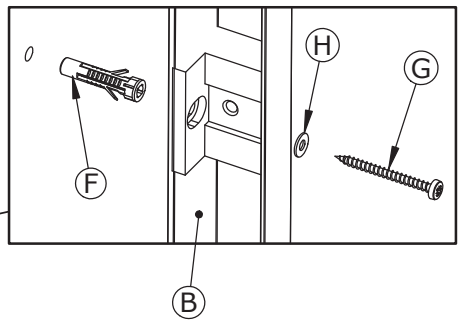
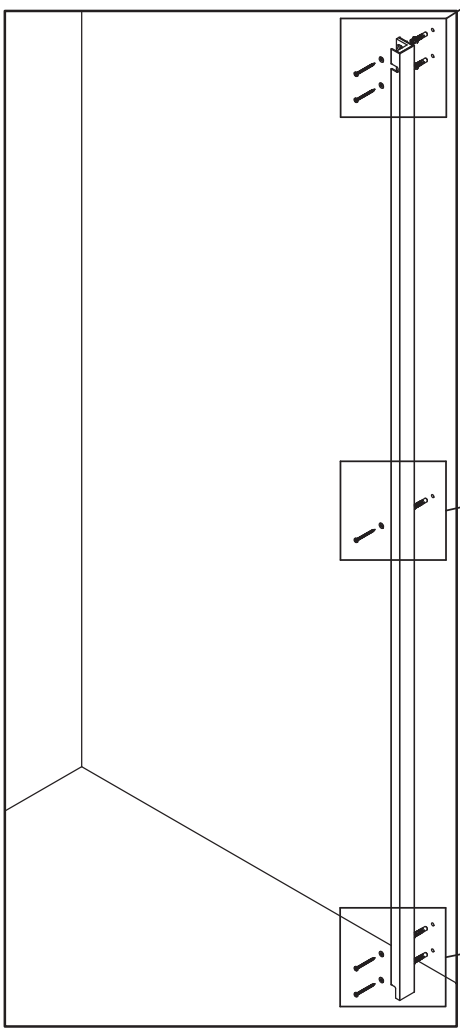
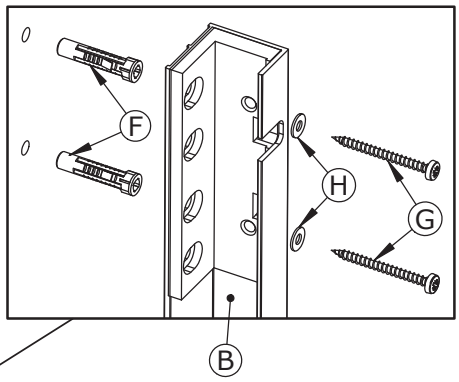

05

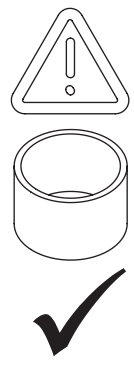
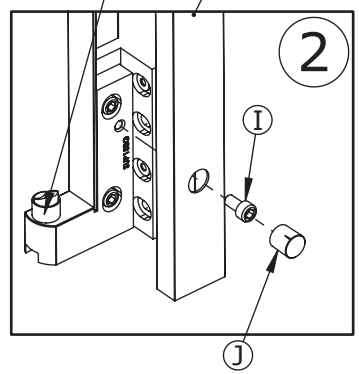
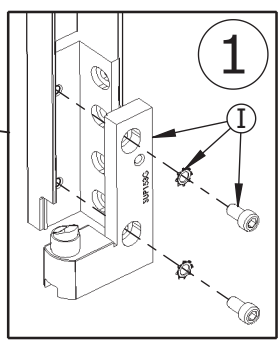
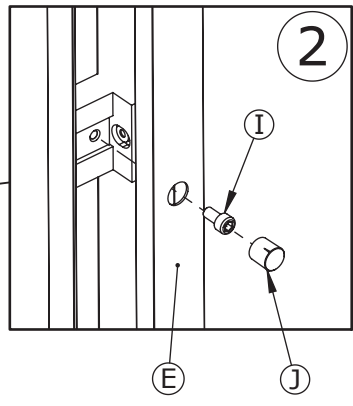
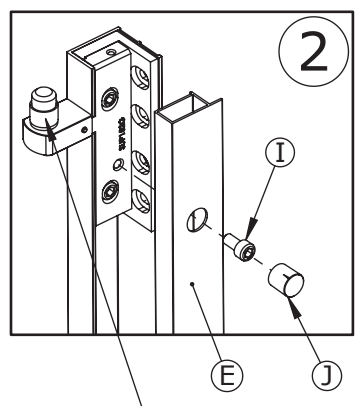
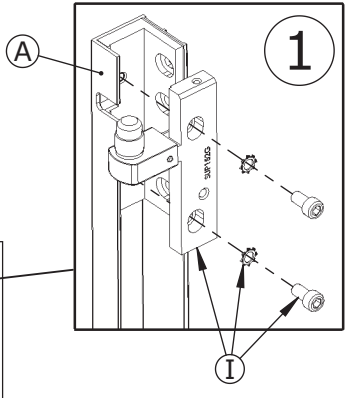
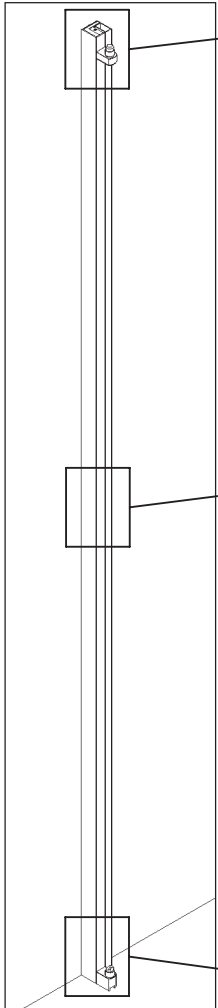

06

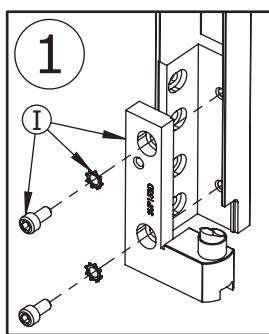
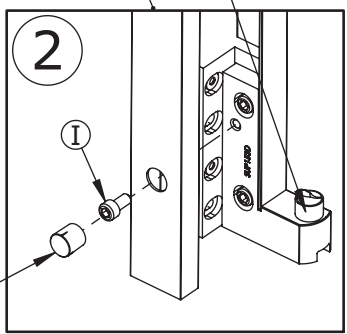
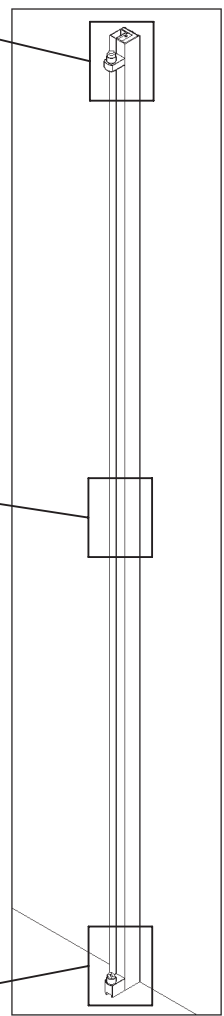
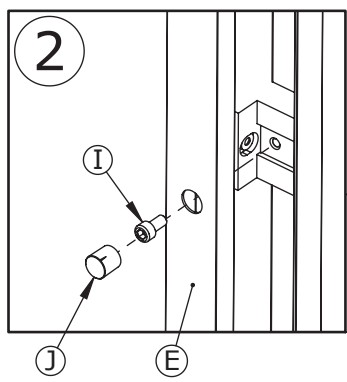
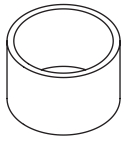
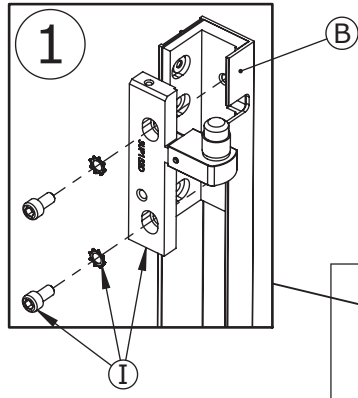
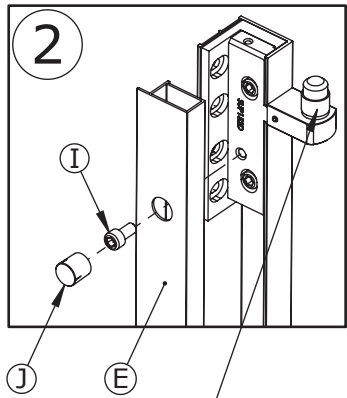

07

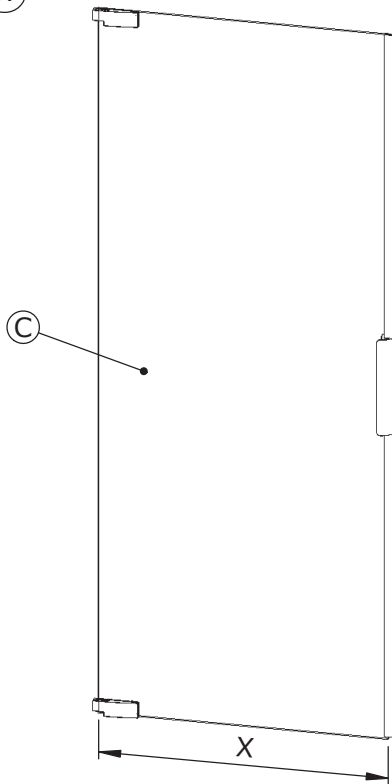

EXTERIEUR
 OUTSIDE
 EXTERIOR
 ESTERNO
 BUITENKANT
 AUßEN

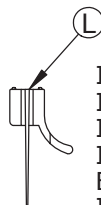

INTERIEUR
 INSIDE
 INTERIOR
 INTERNO
 BINNENKANT
 INNEN

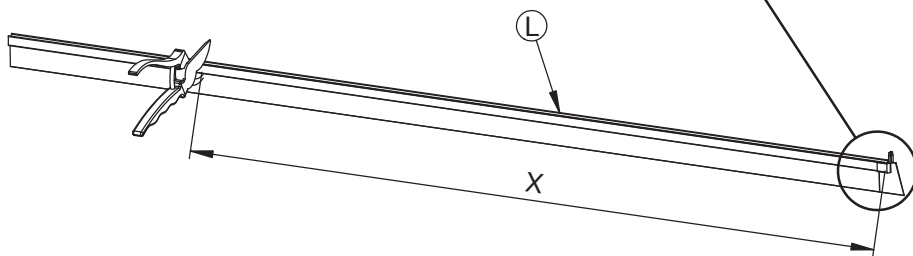
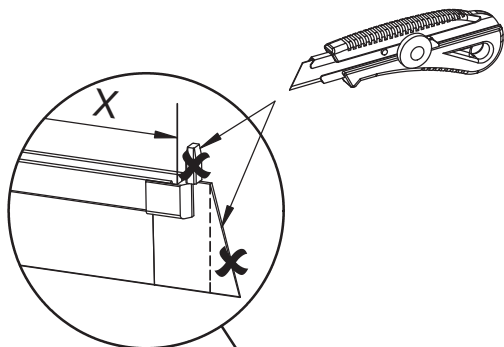

08

INTERIEUR
INSIDE
INTERIOR
INTERNO
BINNENKANT
INNEN



EXTERIEUR
OUTSIDE
EXTERIOR
ESTERNO
BUITENKANT
AUBEN

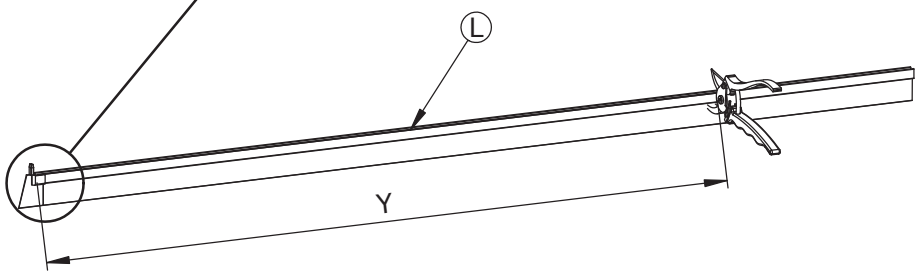
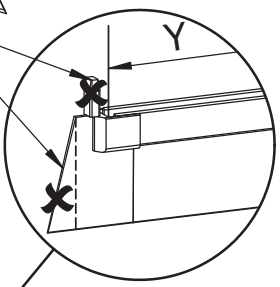
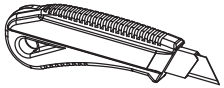
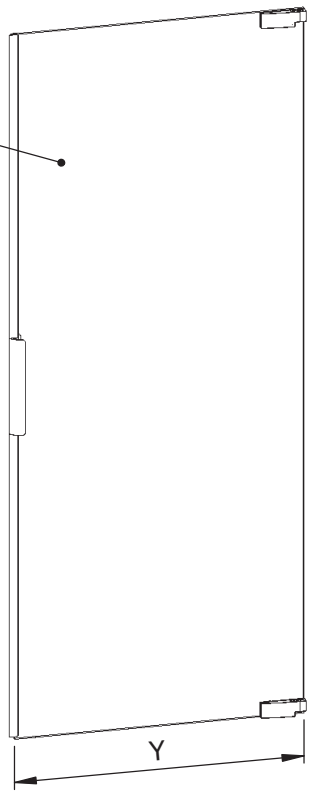

09

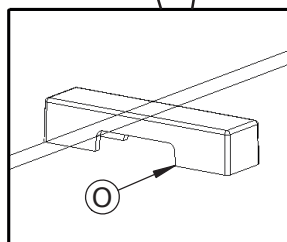
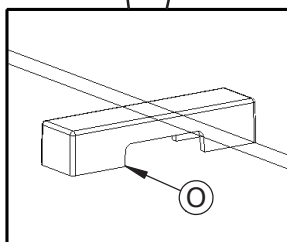
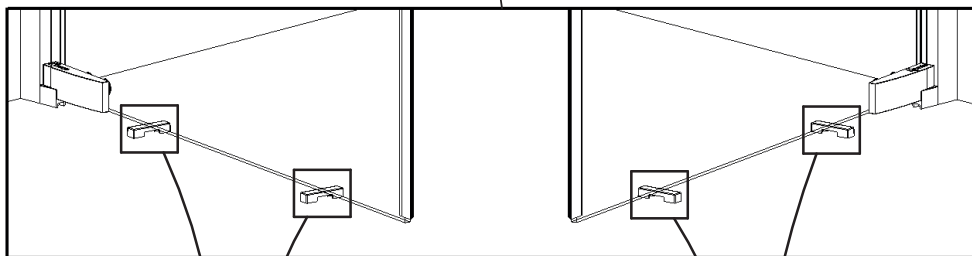
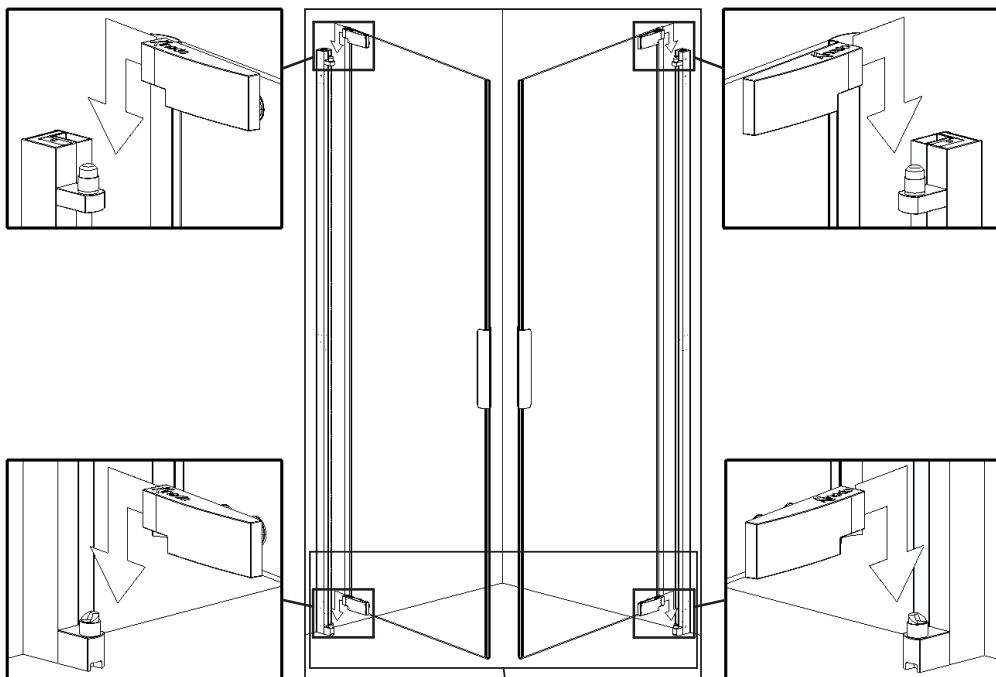

10

Si nécessaire, desserrer, régler l'aplomb et l'aimantation, puis resserrer (Couple de serrage : 9N.m).

If necessary, loosen the screws, check the level, line up the magnetic strips and re-tighten (Tightening torque : 9N.m).

Se necessario svitare, regolare a piombo e poi serrare (Coppia di serraggio : 9N.m).

Si fuese necesario, aflojar, nivelar la puerta y el imán y luego volver a apretar (Par de apriete : 9N.m).

Indien nodig, losschroeven, magneetstrips afstellen en opnieuw vastschroeven (Aandraaimoment : 9N.m).

Sofern erforderlich, Schrauben lösen, Senkrechte und Magnetisierung einstellen, wieder festschrauben (Anzugsdrehmoment : 9N.m).

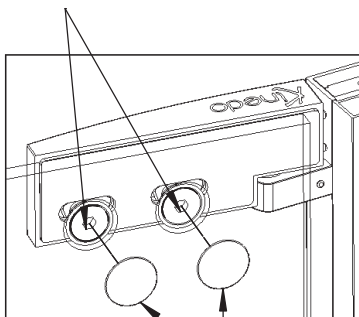
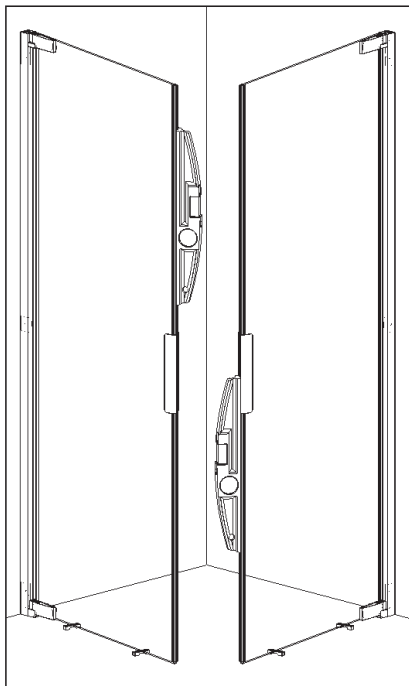

X4

P

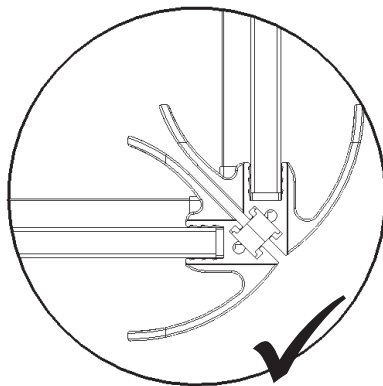
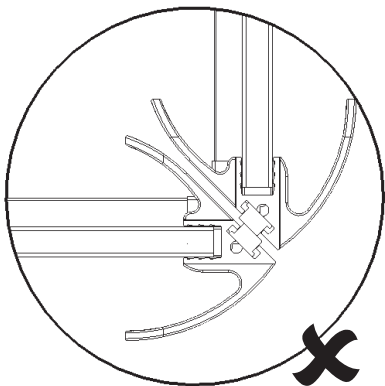

11

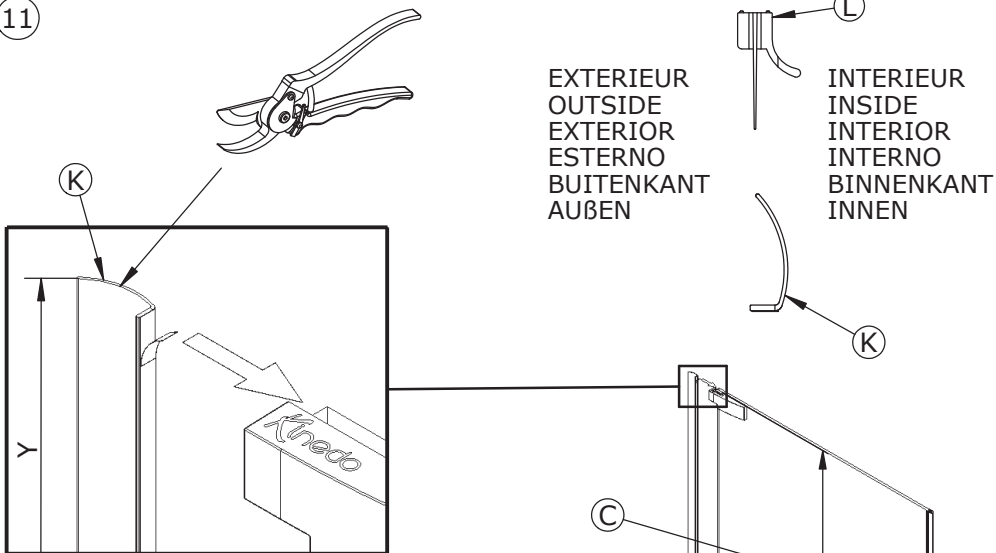

Avant de coller le joint (K), la surface doit être nettoyée, dégraissée et sans poussière, avec un nettoyant à base d'alcool.
Before to put the seal (K), the surface must be cleaned, degreased and without dust with alcohol based cleaner.

Prima di incollare la guarnizioni (K), la superficie deve essere pulita, sgrassata e senza polvere, con un detergente a base di alcool.

Antes de poner la junta (K), la superficie debe limpiarse, desengrasa y sin polvo, con un limpiador a base de alcohol.

Vóór het lijmen van de afdichting (K), moet het oppervlak worden gereinigd, ontvet en stofvrij, met een basis van alcohol reinigingsmiddel.

Bevor das Fugen zu kleben (K), soll die Oberfläche zu reinigen, entfetten und staubfrei, mit einem alkoholhaltigen Reinigungsmittel.

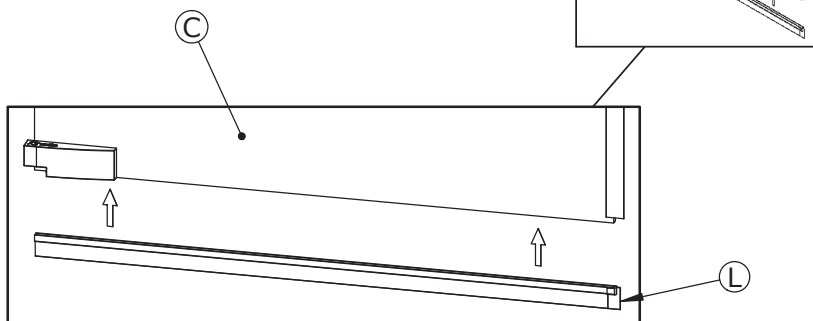

12

INTERIEUR
INSIDE
INTERIOR
INTERNO
BINNENKANT
INNEN

EXTERIEUR
OUTSIDE
EXTERIOR
ESTERNO
BUITENKANT
AUßEN

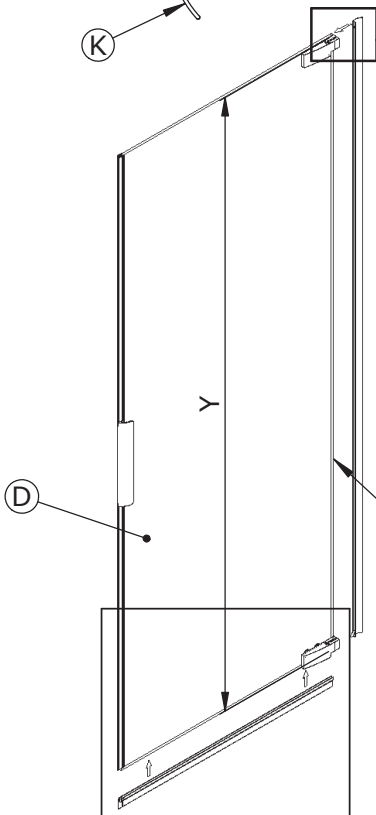
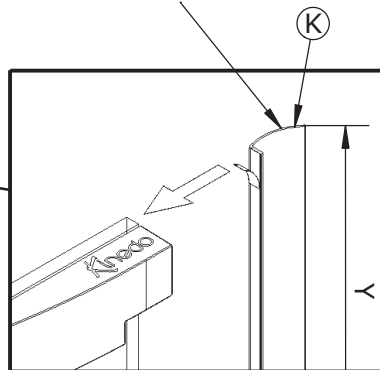
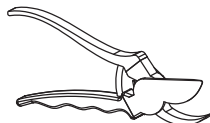
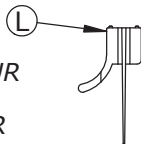

Avant de coller le joint (K), la surface doit être nettoyée, dégraissée et sans poussière, avec un nettoyeur à base d'alcool.

Before to put the seal (K), the surface must be cleaned, degreased and without dust with alcohol based cleaner.

Prima di incollare la guarnizioni (K), la superficie deve essere pulita, sgrassata e senza polvere, con un detergente a base di alcool.

Antes de poner la junta (K), la superficie debe limpiarse, desengrasa y sin polvo, con un limpiador a base de alcohol.

Vóór het lijmen van de afdichting (K), moet het oppervlak worden gereinigd, ontvet en stofvrij, met een basis van alcohol reinigingsmiddel.

Bevor das Fugen zu kleben (K), soll die Oberfläche zu reinigen, entfetten und staubfrei, mit einem alkoholhaltigen Reinigungsmittel.

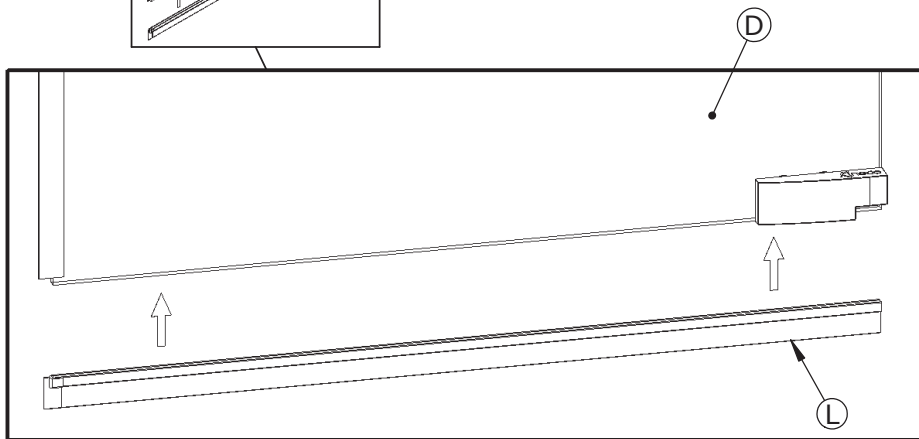

13

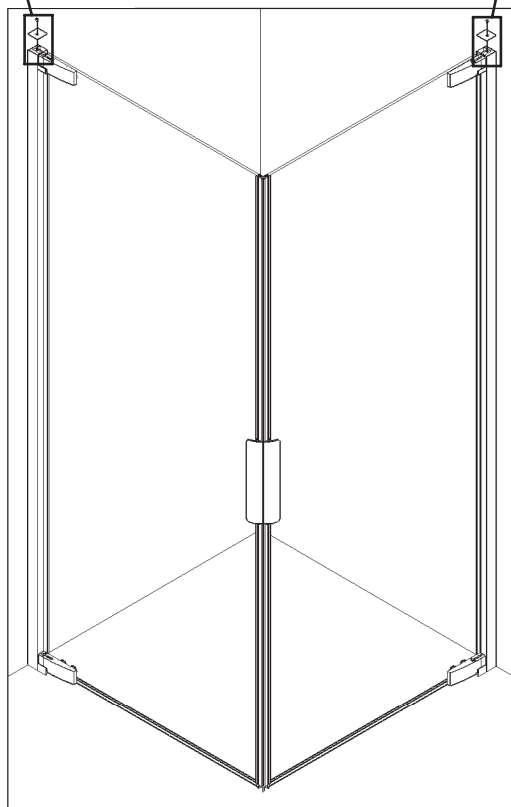
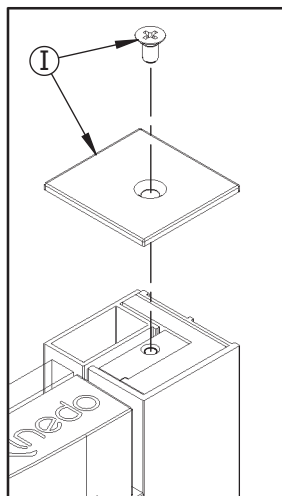
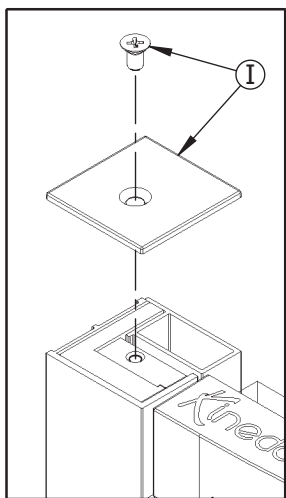

14

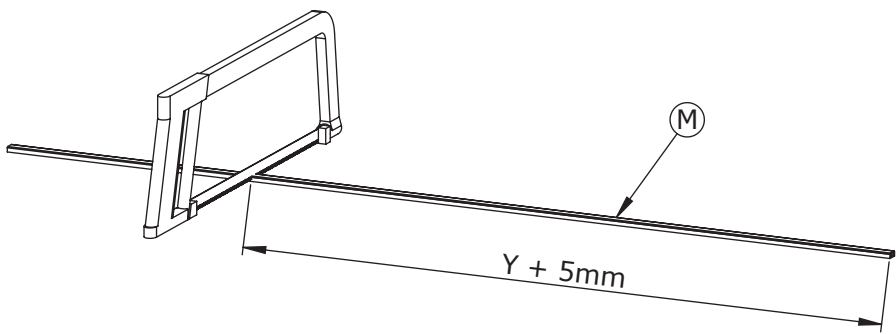
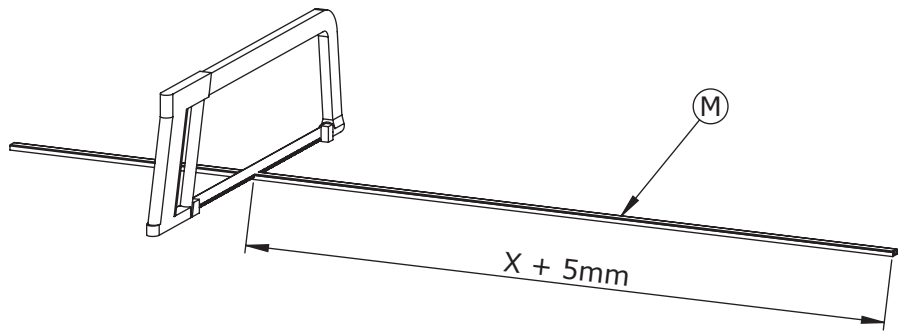
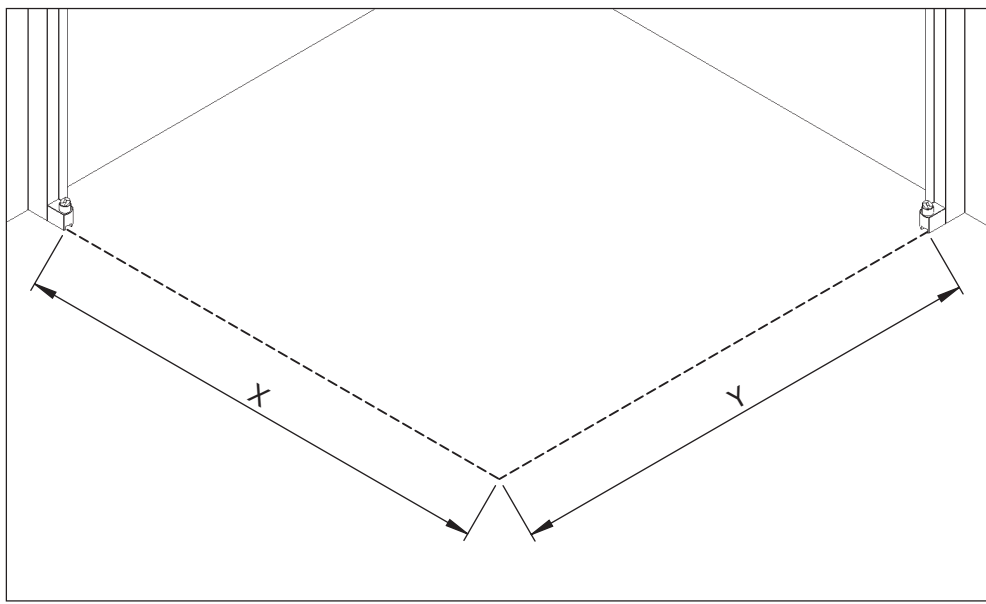

15

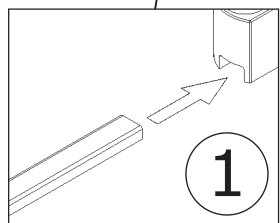
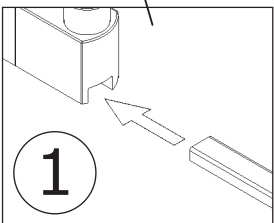
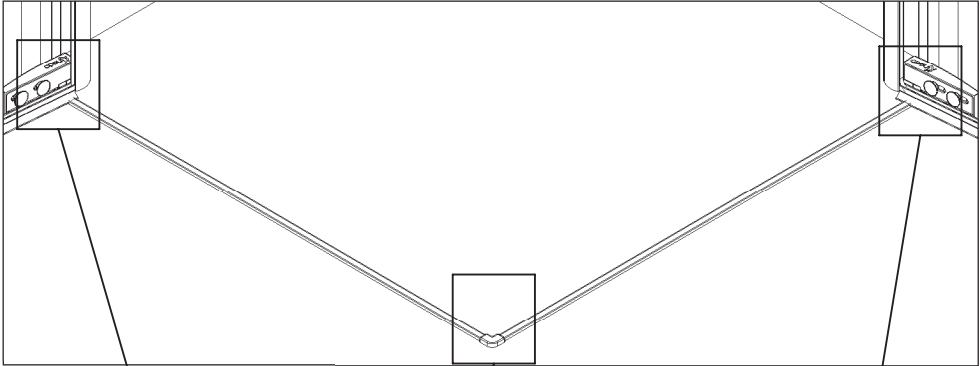
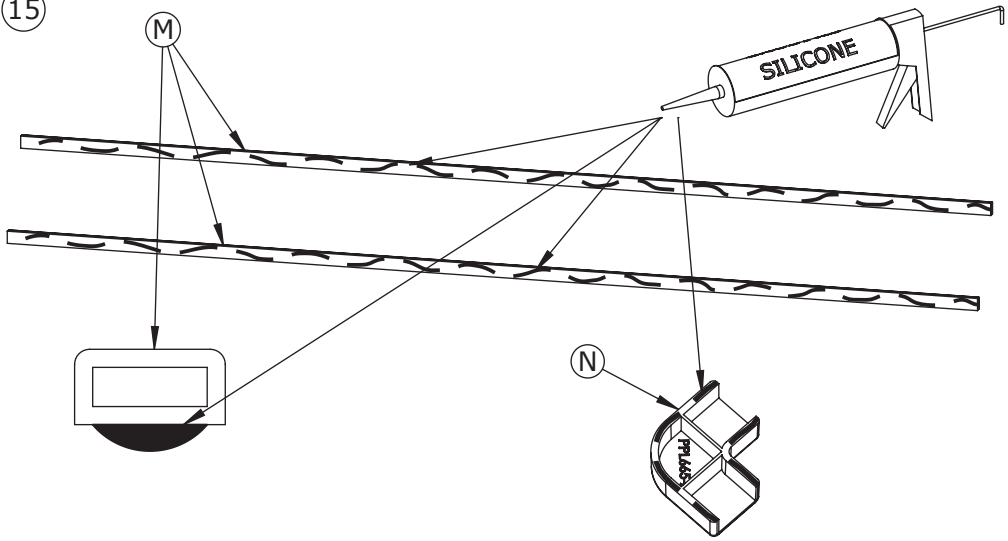

2

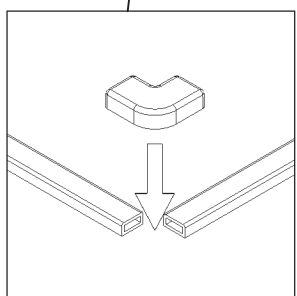

16



24H

Laisser la porte ouverte le temps du séchage
 Leave the door open while the silicon is drying
 Lasciare la porta aperta per il tempo di asciugatura
 Dejar la puerta abierta mientras se seque
 Laat de deur open terwijl de silicone droogt
 Lassen Sie die Tür geöffnet, bis das Silikon getrocknet ist

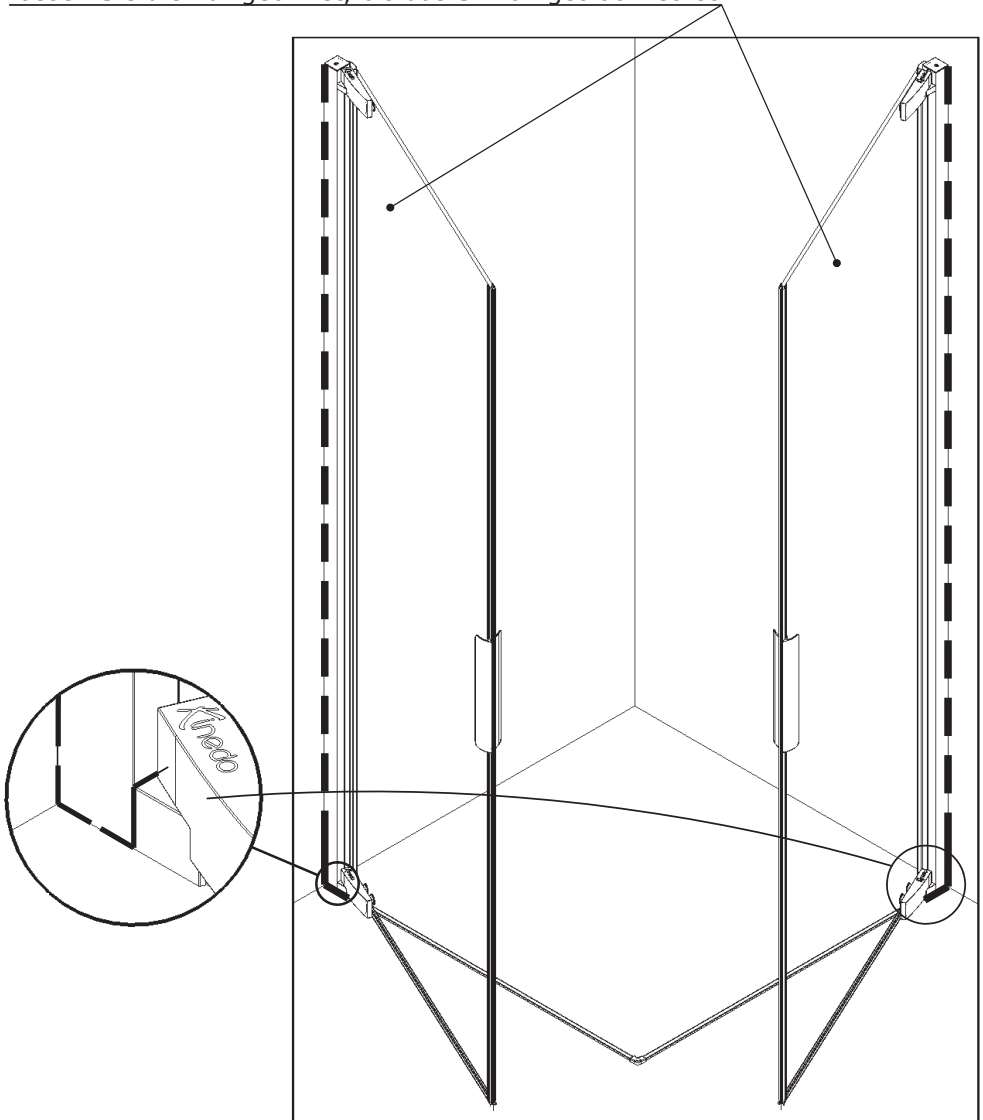



AQUAPRODUCTION, Site industriel, F - 44680 Chéméré

16

EN 14428

Paroi de douche, fabriquée en verre de silicate
sodo-calcique de sécurité trempé thermiquement

Aptitude au nettoyage : réussite

Résistance à l'impact/propriétés de fragmentation : réussite

Durée : réussite



SAV
SERVICE HELPLINES
ASSISTENZA POST-VENDITA
SERVICIO POSTVENTA

FRANCE

02 40 21 29 45

SCHWEIZ

(01) 748 17 44

UK

020 8842 0033

ESPANA

93 544 60 76

IRELAND

04697 33102

NEDERLAND

0475 487 100

DEUTSCHLAND

+49 (0) 6074 / 30928 0

BELGIE

+31 475 487 100

ITALIA

(0382) 6181

BELGIQUE

+31 475 487 100

OSTEREICH

+43 1 710 60 70

РОССИЯ

963 19 40, 773 67 22